

Starcoat™ T5

High Efficiency & High Output ranges
Product Information for Original Equipment Manufacturers

DESCRIPTION

Starcoat™ T5 lamps are triphosphor fluorescent lamps with 16mm outer diameter (5/8 of an inch). These lamps feature “Starcoat Technology” that delivers high quality triphosphor performance.

GE produces 2 ranges of Starcoat™ T5 lamps with equivalent length in each:

- High Efficiency offering high lumens per watt
- High Output offering improved lumen package

High Efficiency Lamps

The High Efficiency range of Starcoat™ T5 brings lumen efficacy to over 100 lm/W. Combined with an extremely long service life, this range of lamps is ideally suited to commercial and retail application in both direct and combined direct/indirect luminaires.

High Output Lamps

The extremely high surface illuminance of the High Output Starcoat™ T5 range makes these lamps ideal for indirect luminaires. These are the best suited to uplighting systems or direct lighting in high ceilings applications, such as those in canopies or industrial situations.

For easy recognition of the two ranges the High Efficiency was stamped with silver ink, the High Output range has gold monogramming.

APPLICATION AREAS

- Retail
- Office
- Schools
- Commercial
- Industrial
- Sports halls



FEATURES

- High efficiency - up to 104 lumens per watt - for ongoing cost savings
- Reduced environmental impact - only 5mg mercury
- Easy fitting of the T5 luminaires into the ceiling module system
- High lumen output - up to 7000 lumens - for improved system efficacy and reduced number of fittings
- Smaller physical dimensions for improved light output control and smaller, more aesthetic fittings
- Peak lumen output at 35° C for optimum light output within fittings
- Less raw material than T8 lamps (glass, packaging materials)
- Designed for HF-operation: higher lamp efficacy and lower ballast losses than conventional ballasts.

COMPLIANCE WITH IEC STANDARDS

GE Lighting T5 linear fluorescent lamps comply with IEC 60061, IEC 60081 and IEC 61195.

STARCOAT™ TECHNOLOGY

Starcoat™ is a proprietary coating technology that eliminates the need for traditional lower quality halophosphor coat by reflecting the UV-light more effectively. This leaves a pure triphosphor coating for the best colour rendering and lumen maintenance possibilities.

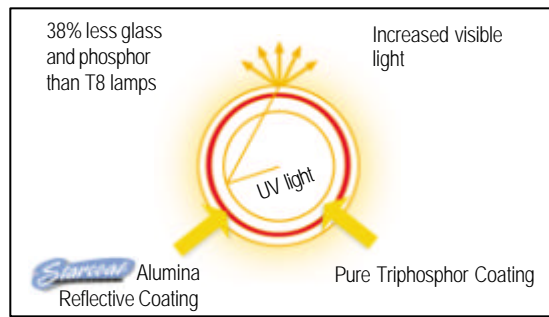

LAMP OPERATION

The light output of a low-pressure mercury vapor lamp is determined by the saturated mercury gas pressure which in turn depends on the temperature of the liquid mercury deposited somewhere onto the inner wall of the lamp. In a stabilized lamp this is the coldest spot of the bulb: the cold chamber.

In case of a Starcoat™ T5 linear fluorescent lamp this spot is situated behind the electrode of the stamp side end. Starcoat™ T5 lamps were designed to reach their maximum luminous flux at an ambient draught-free air temperature of 35°C. As the cold spot is situated near to the metal cap, the temperature of the cap is a good indicator whether the optimum Hg pressure was reached within the lamp: cap temperature of approx. 43-45°C corresponds to maximum light output conditions within a stabilized T5 lamp

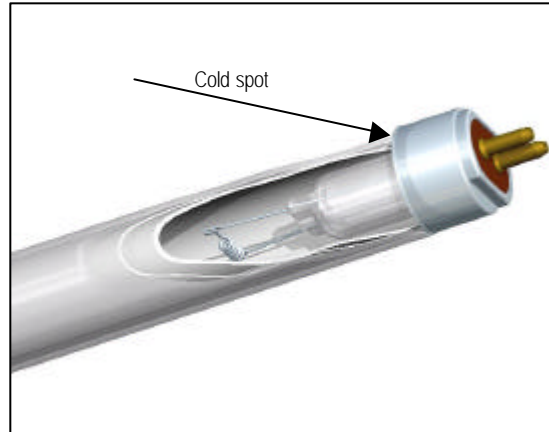

RECOMMENDATIONS FOR MEASURING STARCOAT™ T5 LAMPS

Proper lamp handling is essential when measuring the stable light output of a Starcoat™ T5 lamp. In order to minimize stabilization time try to handle T5 lamps in vertical position with the cold chamber at the lowest point as much as possible.

During measurements the luminous flux of tested lamps should be stabilized. Stable light output condition is reached when all the liquid mercury is in the cold chamber.

Before measuring stable light output Starcoat™ T5 lamps should be seasoned for approx. 100 hours in a vertical position with the cold chamber (stamp side) at the lowest point. If the lamps were switched off for more than 12 hours, burn the lamps for at least 4 hours in vertical position also with cold chamber down. Preparing the lamps and placing the lamps into the test system cold chamber should also be kept at the lowest point as much as possible. After placing the lamp within the test system and before measuring the stable luminous flux lamps should be continuously burnt for 1 hour at 25°C ambient temperature. Stability should be checked by monitoring the luminous flux. The measured luminous flux may be considered stable if relative changes in light output are less than 0.5% within the last 5 minutes.

T5

Lamp operation

RECOMMENDATIONS FOR BALLAST DESIGN

Starcoat™ T5 lamps have electrodes with emissive material which needs to be heated to sufficiently high temperature. Recommended method of starting a Starcoat™ T5 lamp is to heat the electrodes to this high temperatures prior to applying the open circuit voltage to the required values that will cause an ignition. For further information on ballasts please refer to IEC publications 60929: “A.C. supplied electronic ballasts for tubular fluorescent lamps. Performance requirements.”

Emergency Operation

Emergency operation is very important application for T5. During emergency mode the lamp is running on lower lamp current and the emergency are not applying cathode heating. So this operational mode is sputtering of the emitter material due to the low cathode temperature. Emergency ballast makers should contact GE Lighting regarding this matter.

End of lamp life behavior

The normal end-of-life situation for Starcoat T5 lamps is when the emitter depletion of one of the electrodes. In most cases the discharge will distinguish and the lamp will not start again. In some cases the ballast is capable of sustaining the arc even if the above mentioned condition occurs. The voltage drop will rise in this case and extra power dissipation will take place in front of the cathodes. This could lead to overheating of the caps ,glass around them and the lampholders. So the ballast should limit the lower or switch-off when detecting this. In symmetric voltage case both cathodes are deactivated or broken. The ballast should switch off in symmetric and assymetric case also. In addition the ballast should control the supplied preheating, in order to avoid the overheating in case of hard or no starting of lamps without emission material.

Dimming

Dimming is done by reducing the discharge current. As the discharge is lower then the power dissipation in the electrodes will decrease which will result in a lower temperature of the electrode. So additional cathode heating should be applied to the cathodes in order to maintain its temperature. Limits and target setting for the currents will be published later. Under 10% of the discharge current the ballasts will be tested for lamp life.

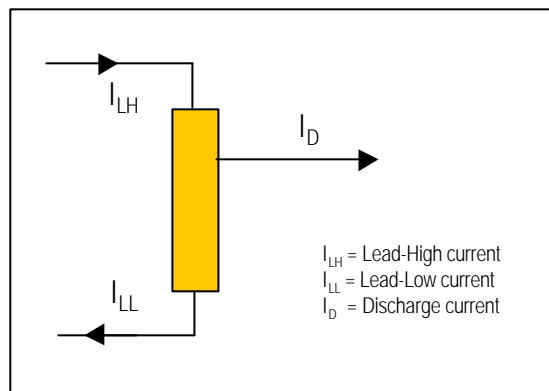

Further considerations on system design

If the design of the luminaire allows higher or lower ambient temperature than 35°C then the luminous output would be different from the designed maximum light output.

In case when additional cathode heating is applied by an electronic gear during lamp operation than this power dissipation may substantially increase the temperature of the cold chamber located behind the electrode. In turn this will result in a shift of the peak light output toward temperature ranges below 35°C.

Air movement within the luminaires can also substantially affect the light output of the T5 lamps since it may also change the cold spot temperature.

Lamp Type		14W	21W	28W	35W
General					
Nominal wattage	W	14	21	28	35
Cap		G5			
Operation		High Frequency			
Cathode		Preheated			
Recommended burning position		horizontal			
Available correlated colour temperature range	K	2700, 3000, 3500, 4000, 6500			

Ordering information (40-way bulk pack)					
827 - CCT 2700K		39965	39975	39980	39986
830 - CCT 3000K		39964	39976	39982	39989
835 - CCT 3500K		39961	39977	39983	39990
840 - CCT 4000K		39973	39978	39984	39991
865 - CCT 6500K		90222	39979	39985	39992

Electrical and photometric characteristics at 25°C					
Rated wattage	W	14	20,6	27,9	35,5
Rated lamp voltage	V	86	126	166	205
Rated lamp current	A	0,165	0,165	0,170	0,175
Operating frequency	kHz	> 20	> 20	> 20	> 20
Rated luminous flux	lm	1230	1910	2640	3320
Rated luminous flux for 865	lm	1140	1770	2450	3090
Temperature range (90% light output, horizontal)	°C	+25...45	+25...45	+25...45	+25...45
Colour rendering index	Ra	85	85	85	85
Typical UV PET	h	>100	>100	>100	>100

Typical lamp characteristics at 35°C					
Lamp wattage	W	13,7	20,7	27,8	34,7
Lamp voltage	V	82	123	167	209
Lamp current	A	0,170	0,170	0,170	0,170
Luminous flux	lm	1350	2100	2900	3650
Luminous flux for 865	lm	1250	1950	2700	3400
Luminous efficacy @ 35 °C	lm/W	96	100	104	104

Lifetime performance					
Lumen maintenance (@ 10 000 h)	%	92	92	92	92
Rated life (2h45min on, 15 min off cycle)	h	20,000	20,000	20,000	20,000
Rapid cycling switches (30 s on, 4.5 min off)	cycles	> 20,000	> 20,000	> 20,000	> 20,000

Starting characteristics					
Preheat current for starting test	A	0,210	0,210	0,210	0,210
Preheat time for starting test	s	2	2	2	2
Starting time	s	0,1	0,1	0,1	0,1

Lamp Type		14W	21W	28W	35W
Cathode characteristics					
Cold resistance	Ω	9	9	9	9
Test current (providing Rh/Rc = 4.75)	A	0,160	0,160	0,160	0,160
Resistance of each cathode at test current	Ω	40	40	40	40

Reference ballast characteristics					
Frequency	kHz	20...26	20...26	20...26	20...26
Nominal wattage	W	14	21	28	35
Rated voltage	V	167	246	329	413
Calibration current	A	0,170	0,170	0,170	0,170
Resistance	Ω	500	725	950	1200

Information for HF ballast design					
Frequency	kHz	> 20	> 20	> 20	> 20
Current in any lead to cathodes	A	< 0.220	< 0.220	< 0.220	< 0.220
Lamp operating current	A	0.130...0.205	0.130...0.205	0.130...0.205	0.130...0.205

Starting requirements with cathode preheating					
E _{min} = Q + P · t _s (t _s = 0.4...3.0 s)					
Q	J	0,9	0,9	0,9	0,9
P	W	0,75	0,75	0,75	0,75
R _{sub}	Ω	30	30	30	30
E _{max} = F x E _{min}		1,75	1,75	1,75	1,75
Voltage across each cathode for E(t) < E _{min}	V	< 10	< 10	< 10	< 10
Open circuit voltage (V _{rms}) across lamp					
t < t _b	V	130	200	240	275
t > t _b at 10 °C	V	230	340	425	530
t > t _b at -15 °C	V	275	390	530	700
Substitution resistor for each cathode	Ω	30 90	30 90	30 90	30 90

Luminous flux					
I _{LH} ² + I _{LL} ² Minimum		A - B x I _d	A - B x I _d	A - B x I _d	A - B x I _d
		under consideration			
I _{LH} ² + I _{LL} ² Target		G - H x I _d	G - H x I _d	G - H x I _d	G - H x I _d
		under consideration			
Lamp operating current with additional cathode heat	A	0.020 ... 0.130	0.020 ... 0.130	0.020 ... 0.130	0.020 ... 0.130
Minimum operating current without additional heat current	A	0,130	0,130	0,130	0,130

Safety requirements					
Maximum allowed cap temperature under abnormal conditions	°C	120	120	120	120
Maximum cap temperature rise	°C	75	75	75	75
Maximum lamp operating current	A	0,205	0,205	0,205	0,205

Dimensions					
A Max - base to base	mm	549,0	849,0	1149,0	1449,0
B Min - pin to base	mm	553,7	853,7	1153,7	1453,7
B Max - pin to base	mm	556,1	856,1	1156,1	1456,1
C Max - pin to pin	mm	563,2	863,2	1163,2	1463,2
D Max - outer diameter	mm	17	17	17	17

Lamp Type		24W	39W	54W	49W	80W
General						
Nominal wattage	W	24	39	54	49	80
Cap		G5	G5	G5	G5	G5
Operation		High Frequency				
Cathode		Preheated				
Recommended burning position		horizontal				
Available correlated colour temperature range	K	2700, 3000, 3500, 4000, 6500				

Ordering information (40-way bulk pack)						
827 - CCT 2700K		39994	90200	90205	90220	90225
830 - CCT 3000K		39998	90201	90232	90219	90226
835 - CCT 3500K		90196	90202	90206	90221	90227
840 - CCT 4000K		90197	90203	90209	90223	90228
865 - CCT 6500K		90198	90204	90211	90224	90229

Electrical and photometric characteristics at 25°C						
Rated wattage	W	22,5	38	54,1	49,2	79,8
Rated lamp voltage	V	77	118	120	195	152
Rated lamp current	A	0,295	0,325	0,455	0,255	0,530
Operating frequency	kHz	> 20	> 20	> 20	> 20	> 20
Rated luminous flux	lm	1750	3200	4460	4450	6450
Rated luminous flux for 865	lm	1600	2950	4100	4100	5950
Temperature range (90% light output, horizontal)	°C	+25...45	+25...45	+25...45	+25...45	+25...45
Colour rendering index	Ra	85	85	85	85	85
Typical UV PET	h	>100	>100	>100	>100	>100

Typical lamp characteristics at 35°C						
Rated wattage	W	22,5	38	53,8	49,3	80
Lamp voltage	V	75	112	117	191	145
Rated lamp current	A	0,300	0,340	0,460	0,260	0,555
Luminous flux	lm	2000	3500	5000	4900	7000
Luminous flux for 865	lm	1900	3330	4750	4650	6650
Luminous efficacy at 35°C	lm/W	84	90	93	100	88

Lifetime performance						
Lumen maintenance at 10 000h	%	92	92	92	92	92
Rated life (2h45min on, 15 min off cycle)	h	20,000	20,000	20,000	20,000	20,000
Rapid cycling switches (30 s on, 4.5 min off)	cycles	> 20,000	> 20,000	> 20,000	> 20,000	> 20,000

Starting characteristics						
Preheat current for starting test	A	0,440	0,440	0,720	0,330	0,765
Preheat time for starting test	s	2	2	2	2	2
Starting time	s	0,1	0,1	0,1	0,1	0,1

Lamp Type		24W	39W	54W	49W	80W
Cathode characteristics		S				
Cold resistance	Ω	2,5	2,5	1,7	3,5	1,5
Test current (providing Rh/Rc = 4.75)	A	0,350	0,350	0,500	0,260	0,550
Resistance of each cathode at test current	Ω	12	12	8,5	17	7,5

Reference ballast characteristics						
Frequency	kHz	20...26	20...26	20...26	20...26	20...26
Nominal wattage	W	24	39	54	49	80
Rated voltage	V	150	224	234	390	290
Calibration current	A	0,300	0,340	0,460	0,255	0,555
Resistance	Ω	250	330	255	765	260

Information for HF ballast design						
Frequency	kHz	> 20	> 20	> 20	> 20	> 20
Current in any lead to cathodes	A	< 0.450	< 0.450	< 0.650	< 0.330	< 0.715
Lamp operating current	A	0.270 ... 0.435	0.270 ... 0.435	0.370 ... 0.625	0.180 ... 0.295	0.440 ... 0.670

Starting requirements with cathode preheating						
E _{min} = Q + P · t _s (t _s = 0.4...3.0 s)						
Q	J	1,5	1,5	2	0,8	2
P	W	0,9	0,9	1	0,7	1
R _{sub}	Ω	8	8	5	12,5	4,5
E _{max} = F x E _{min}		1,75	1,75	1,75	1,75	1,75
Voltage across each cathode for E(t) < E _{min}	V	< 10	< 10	< 10	< 10	< 10
Open circuit voltage (V _{rms}) across lamp						
t < t _b	V	130	175	240	225	250
t > t _b at 10 °C	V	280	350	520	450	580
t > t _b at -15 °C	V	350	390	620	625	750
Substitution resistor for each cathode	Ω	8 24	8 24	4.8 14.4	12 36	4.5 13.5

Luminous flux						
I _{LH} ² + I _{LL} ² Minimum		A - B x I _d	A - B x I _d	A - B x I _d	A - B x I _d	A - B x I _d
under consideration						
I _{LH} ² + I _{LL} ² Target		G - H x I _d	G - H x I _d	G - H x I _d	G - H x I _d	G - H x I _d
under consideration						
Lamp operating current with additional cathode heat	A	0.030 ... 0.270	0.030 ... 0.270	0.050 .. 0.370	0.025 ... 0.180	0.055 ... 0.440
Minimum operating current without additional heat curre	A	0,270	0,270	0,370	0,180	0,440

Safety requirements						
Maximum allowed cap temperature under abnormal coi	°C	120	120	120	120	120
Maximum cap temperature rise	°C	75	75	75	75	75
Maximum lamp operating current	A	0,425	0,425	0,625	0,295	0,670

Dimensions						
A Max - base to base	mm	549,0	849,0	1149,0	1449,0	1449,0
B Min - pin to base	mm	553,7	853,7	1153,7	1453,7	1453,7
B Max - pin to base	mm	556,1	856,1	1156,1	1456,1	1456,1
C Max - pin to pin	mm	563,2	863,2	1163,2	1463,2	1463,2
D Max - outer diameter	mm	17	17	17	17	17

DIMENSIONS

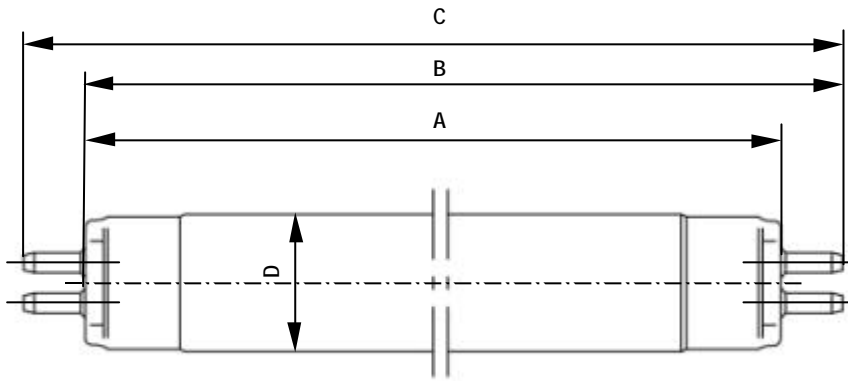

Dimensions		14W	21W	28W	35W
A - Max (base to base)	mm	549,0	849,0	1149,0	1449,0
B - Min (base to pin)	mm	553,7	853,7	1153,7	1453,7
B - Max (base to pin)	mm	556,1	856,1	1156,1	1456,1
C - Max (pin to pin)	mm	563,2	863,2	1163,2	1463,2
D - Max (outer diameter)	mm	17,0	17,0	17,0	17,0

Dimensions		24W	39W	54W	49W & 80W
A - Max (base to base)	mm	549,0	849,0	1149,0	1449,0
B - Min (base to pin)	mm	553,7	853,7	1153,7	1453,7
B - Max (base to pin)	mm	556,1	856,1	1156,1	1456,1
C - Max (pin to pin)	mm	563,2	863,2	1163,2	1463,2
D - Max (outer diameter)	mm	17,0	17,0	17,0	17,0

According to IEC 60081

Cap - G5

IEC 60081 Datasheets 7004-52-5

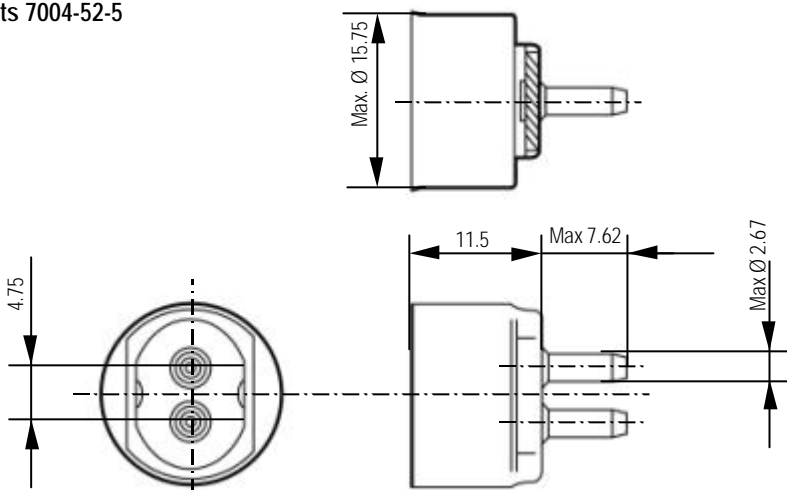

Dimensions measured on finished lamps

LAMP LIFE AND LUMEN MAINTENANCE



Cathodes of a fluorescent lamp lose their electron-emissivity during life due to the evaporation of emission mixture. When the deterioration reaches a certain level, the cathode breaks. Typical lifetime characteristics are based on GE Lighting's measurements according to the relevant IEC standards. The declared lamp life is the median life, which is when 50% of the lamps from a large sample batch would have failed. Real lifetime figures may depend on actual application. For instance improper cathode preheat, too high operating current, or too low operating current without additional cathode heating reduces the expected life.

Lumen maintenance graph shows how the luminous output decreases throughout life. The main causes of the light depreciation are the deterioration of phosphor coating and the lamp blackening due to the deposition of evaporated emission mixture on the glass tube. These effects are unavoidable. Lumen maintenance curve presented here for Starcoat™ T5 lamps is based on lumen readings under laboratory conditions.

Test conditions:

- Photometric sphere
- Horizontal burning position
- Switching cycle: 165 minutes On – 15 minutes Off
- High frequency operation
- 25°C ambient temperature

Burning hours	Survival %
4000	99
8000	99
12000	98
16000	89
20000	50

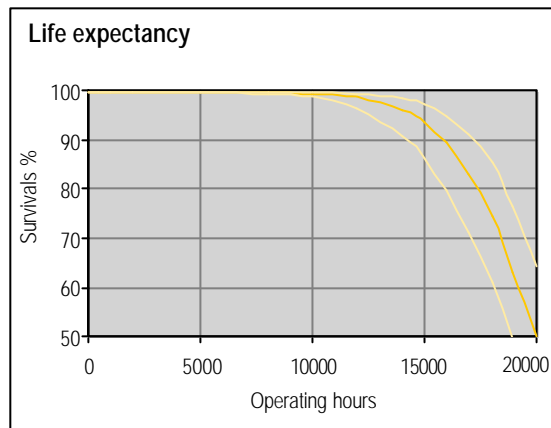

Burning hours	Lumen %
500	97
1000	96
2000	95
5000	93
10000	91
20000	89

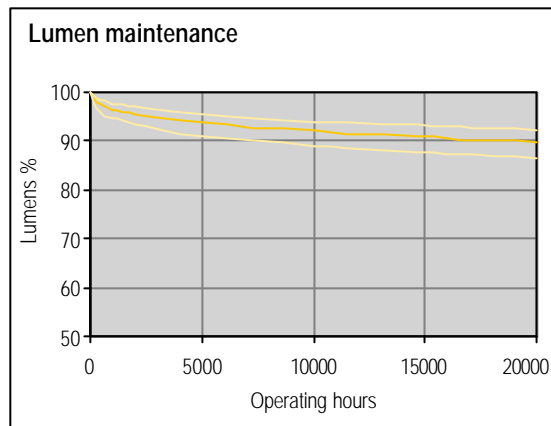

Lamp performance

The lamp performance parameters, such as luminous output, lamp voltage and power depend on the mercury vapour pressure in the discharge tube. The mercury vapour pressure is a function of the thermal conditions around the glass tubes. The burning position, air flow, radiated heat sources have effect on these conditions. The temperature when the maximum lamp light output occurs in reference conditions is 35°C. T5 tubes and commercial ballasts with an electrode heating cut-off have a maximum lamp flux close to 35°C. The diagram below shows the typical behavior of the relative luminous output of a long T5 lamp at horizontal burning position at different ambient still air temperature.

Test conditions:

- thermal chamber with $\pm 2^\circ\text{C}$ accuracy
- draught-free air
- commercial ballasts

T_{amb} (°C)	Relative luminous flux (%) Horizontal burning position
-10	9
-5	14
0	22
5	32
10	45
15	60
20	76
25	91
30	98
35	100
40	97
45	92
50	86
55	82
60	80

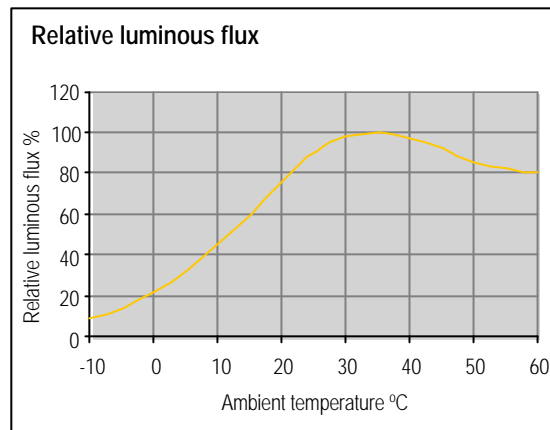

The fall-off rate of the luminous flux - i.e. the ratio of the luminous flux measured at 35°C and 25°C ambient temperature, respectively - may vary in the range between 1.05 and 1.25 depending on lamp type and electronic gear type used during measurement.

Starcoat™ T5 lamps can be ignited from - 20°C to 60°C ambient temperature.

Lamp temperatures

The following charts shows the lamp temperatures at five spots: tube wall near the cathode at both sides, tube wall at the middle of the tube and both caps. Cap temperature was measured according to IEC.

Test conditions:

- thermal chamber with $\pm 2^{\circ}\text{C}$ accuracy
- draught-free air
- Commercial ballast

Ambient Temperature (°C)	Cap A (°C)	Cathode A (°C)	Middle (°C)	Cathode B (°C)	Cap B (°C)
10,0	18,5	50,3	36,4	49,8	23,4
15,0	24,0	54,5	40,7	52,8	27,5
20,0	28,4	59,0	46,2	57,5	32,3
27,0	35,0	65,5	53,5	65,0	39,0
29,7	37,7	69,2	56,3	67,6	41,6
32,4	40,6	71,7	58,8	69,9	44,4
34,5	43,0	73,5	60,8	72,1	46,6
37,5	46,2	76,5	63,3	74,8	49,7
40,2	49,0	78,0	65,2	77,0	52,3
42,2	51,1	79,8	66,7	78,9	54,5
46,9	55,9	83,6	70,0	82,7	59,2
50,1	59,3	86,3	72,4	85,5	62,6

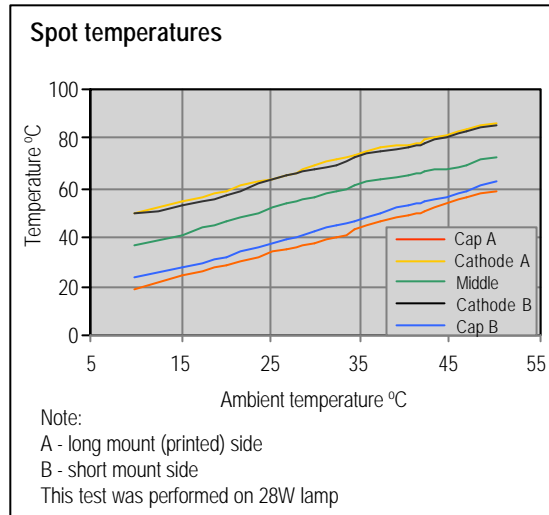

Spectral Power Distribution

Spectral Power Distribution curves are given in the following diagrams.

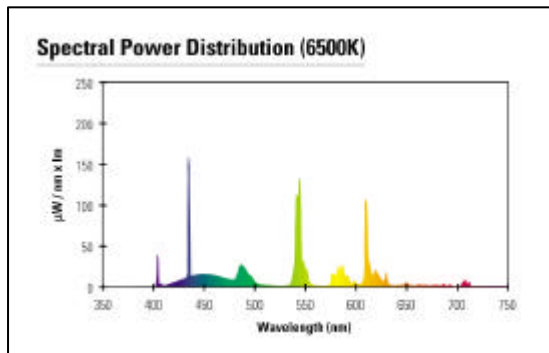
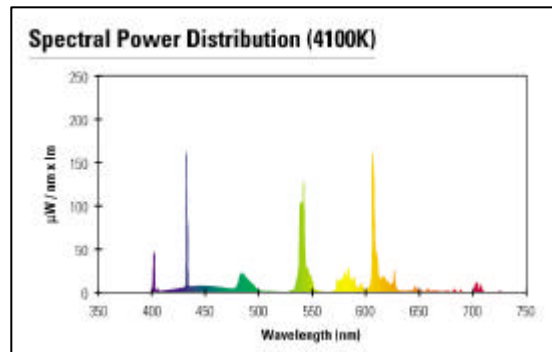
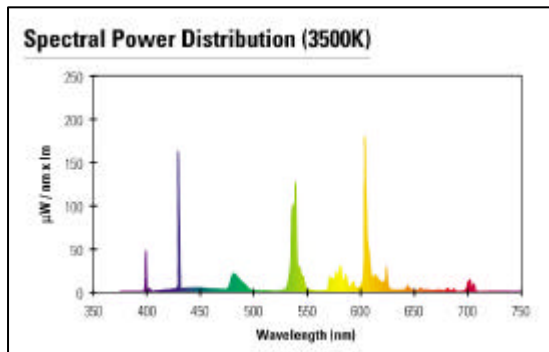
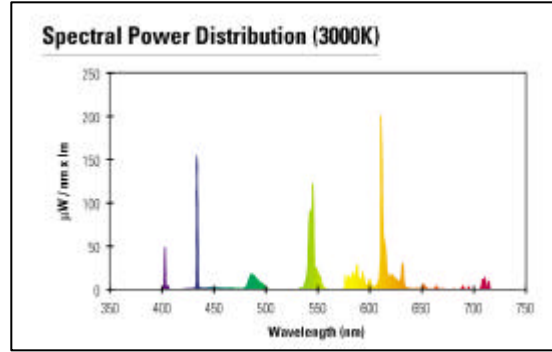
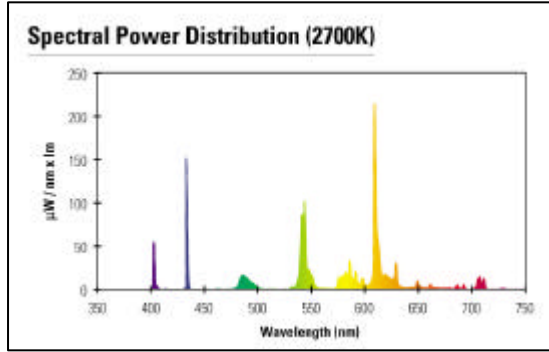

Colour specification according to CIE 1931

CCT (K)	X	Y	CRI
2700	0,463	0,420	85
3000	0,440	0,403	85
3500	0,409	0,394	85
4000	0,380	0,380	85
6500	0,313	0,337	85

PREHEATING REQUIREMENTS



Suitable preheating of cathodes prior to ignition is essential for long lamp life. The preheating requirement can be given by the following formula:

$$E = Q + P \cdot t \quad \text{This energy is measured on a substitution resistor } R_{\text{sub}}$$

Q stands for the necessary thermal energy. P represents the power loss due to the heat transmission from the cathode. The longer the preheating, the more the power loss. The two basic preheating modes, the current controlled and the voltage controlled modes, can be derived from the formula.

Lamp Type	Q (J)	P (W)	Rsub (W)
14W	0,9	0,75	30,0
21W	0,9	0,75	30,0
28W	0,9	0,75	30,0
35W	0,9	0,75	30,0
24W	1,5	0,9	8,0
39W	1,5	0,9	8,0
54W	2,0	1,0	5,0
49W	0,8	0,7	12,5
80W	2,0	1,0	4,5

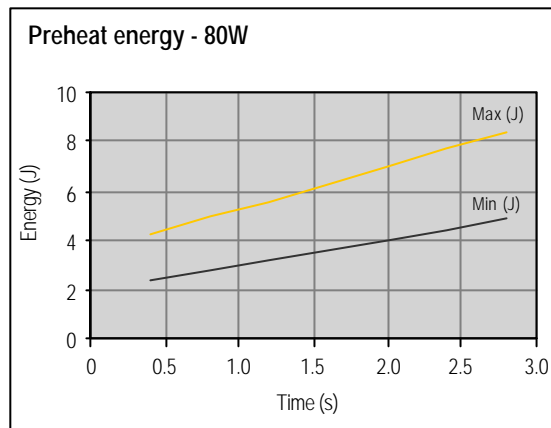
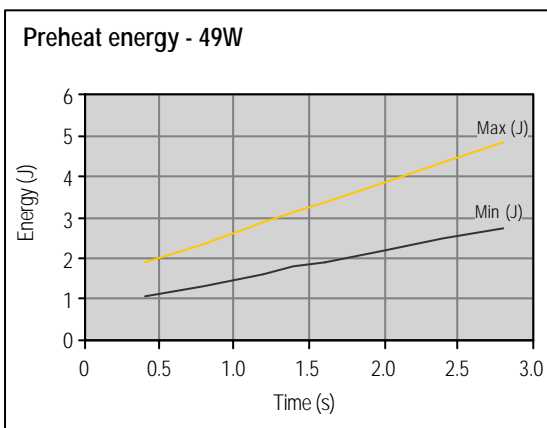
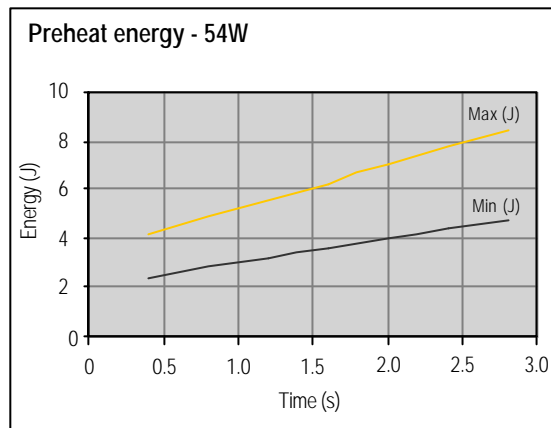
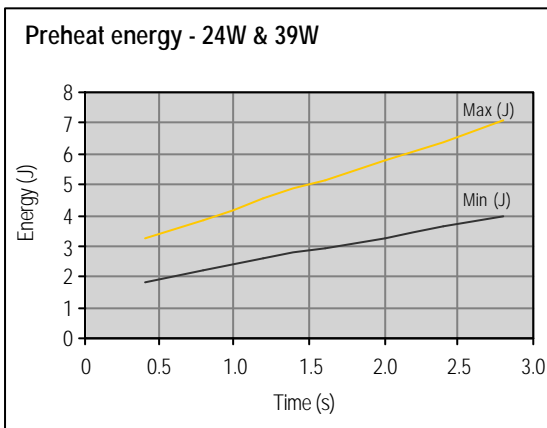
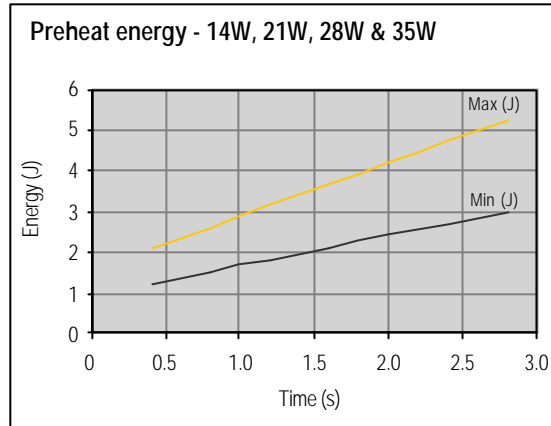

230V electronic ballasts approved by GE Lighting

The list given below is not considered to be comprehensive, but merely indicates the ballasts tested by GE Lighting. Ballasts produced by other reputable control gear manufacturers meeting the relevant IEC standards would also be considered as suitable.

Lamp Type	Manufacturers			
	Tridonic	Helvar	Vossloh	Atlas
1x14W	PC 1/14 T5 PRO PC 1x35/28/21/14 T5	EL 1x14 HF T5	ELXc114.460	GM135 HE
2x14W		EL 2x14 HF T5	ELXc214.461	GM214 HE
3x14W		EL 3x14 HF T5		
4x14W		EL 4x14 HF T5		
1x21W	PC 1x35/28/21/14 T5	EL 1x21 HF T5	ELXc121.462	GM135 HE
2x21W		EL 2x21 HF T5	ELXc221.463	
1x28W	PCA 1/28 T5 EXCEL PC 1x35/28/21/14 T5	EL 1x28 HF T5	ELXc128.464	GM135 HE
2x28W	PCA 2/28 T5 EXCEL	EL 2x28 HF T5	ELXc228.465	GM235 HE
1x35W	PC 1x35/28/21/14 T5	EL 1x35 HF T5	ELXc135.466	GM135 HE
2x35W		EL 2x35 HF T5	ELXc235.467	GM235 HE
1x24W	PC 1x24 T5 PRO			GM124 HO
2x24W				GM224 HO
1x39W	PC 1x39 T5 PRO			
2x39W			ELXc239.483	
1x54W	PC 1x54 T5 PRO			
2x54W				
1x49W	PC 1x49 T5 PRO	EL 1x49 HF T5		
2x49W				
1x80W				

Lamp Type	Manufacturers			
	Magnetek	Clalight	Philips	Osram
1x14W	BBT-114-135 W1	CLT/1UN1435/T5		
2x14W		CLT/2UN1428/T5	HF-P 214 TL5	
3x14W				
4x14W				
1x21W	BBT-114-135 W1	CLT/1UN1435/T5		
2x21W			HF-P 221 TL5	
1x28W	BBT-114-135 W1	CLT/1UN1435/T5	HF-P 128 TL5	QT-FH 1x28
2x28W				
1x35W	BBT-114-135 W1	CLT/1UN1435/T5		
2x35W				
1x24W				
2x24W				
1x39W			HF-R 1x39 TL5	
2x39W			HF-P 2x39 TL5	
1x54W			HF-R 1x54 TL5	
2x54W			HF-P 2x54 TL5	
1x49W				
2x49W			HF-P 2x49 TL5	
1x80W				